



Operation Manual

---

# **CCD CAMERA**

CG-641 Series

- Read the “Instructions for Use” prior to operation.
- Retain this operation manual for future reference.
- Follow these important safety instructions at all times.
- Heed the following explanations of “Warning” and “Caution”.











### Warning

Indicates danger of death or injury to the user if not operated properly.



### Caution

Indicates danger of injury to the user or material damage if not operated properly.

 <h2 style="margin: 0;">Warning</h2>	
	<p><b>Do not open the cover or disassemble the main casing.</b> This may result in burns or injury due to contacting high temperature areas inside the main body or damaged part.</p>
	<p><b>Do not insert foreign objects.</b> Do not spill liquids or drop flammable items or metal inside. This may cause fire. Disconnect the power plug and contact a dealer.</p>
	<p><b>Do not use in conditions such as rain, water, moisture, dust, greasy fumes and hot air.</b> This may cause fire.</p>
	<p><b>Do not place in the vicinity of thermal appliances.</b> This may cause the casing to warp or high temperatures inside the device which could result in fire.</p>
	<p><b>Avoid direct sunlight.</b> This may cause high temperatures inside the device which could result in fire.</p>
	<p><b>Disconnect the cables immediately upon detecting smoke or an unusual odor.</b> Subsequent to disconnecting power, confirm that there is no smoke or unusual odor and contact a dealer. Failing to do so may result in fire.</p>
	<p><b>Do not touch the device or the connecting cables in the case of lightning.</b> This may cause electric shock.</p>
	<p><b>Ask a dealer for installation.</b> Failing to do so may result in fire, electric shock and accident.</p>



## Caution



**Turn off the power before connecting any devices.**

Failing to do so could result in electric shock or fire.



**Make sure that connecting cables are inserted fully.**

Failing to do so can result in fire.



**Disconnect the power and cables before moving the device.**

Failing to do so can result in injury and damage to the device.



**Install connecting cables in an area where they won't be pulled or be caught.**

Failing to do so can result in injury.

# Important Safety Instructions

1. Read these instructions
2. Keep these instructions.
3. Heed all warnings.
4. Follow all instructions.
5. Do not use this apparatus near water.
6. Clean only with dry cloth.
7. Do not block any ventilation openings. Install in accordance with the manufacturer's instructions.
8. Do not install near any heat sources such as radiators, heat registers, stoves, or other apparatus (including amplifiers) that produce heat.
9. Do not defeat the safety purpose of the polarized or grounding-type plug.  
A polarized plug has two blades with one wider than the other.  
A grounding type plug has two blades and a third grounding prong.  
The wide blade or the third prong are provided for your safety.  
If the provided plug does not fit into your outlet, consult an electrician for replacement of the obsolete outlet.
10. Protect the power cord from being walked on or pinched particularly at plugs, convenience receptacles, and the point where they exit from the apparatus.
11. Only use attachments/accessories specified by the manufacturer.
12. Use only with the cart, stand, tripod, bracket, or table specified by the manufacturer, or sold with the apparatus. When a cart is used, use caution when moving the cart/apparatus combination to avoid injury from tip-over.
13. Unplug this apparatus during lightning storms or when unused for long periods of time.
14. Refer all servicing to qualified service personnel. Servicing is required when the apparatus has been damaged in any way, such as power-supply cord or plug is damaged, liquid has been spilled or objects have fallen into the apparatus, the apparatus, the apparatus has been exposed to rain or moisture, does not operate normally, or has been dropped.

PORTABLE CART WARNING  
(Symbol provided by RETAC)



S3125A

# CONTENTS

<u>Item</u>	<u>Page</u>
Introduction.....	4
Cautions for Operation.....	4
External Controls and Connectors.....	5
Lens.....	6
Electronic Connections.....	6
Mechanical Connection.....	6
Lens Adjustment.....	6
Back Focal Length Adjustment.....	7
Power Connection.....	8
AC Power Connection.....	8
DC Power Connection.....	8
Setup Menu.....	9
Settings Operation.....	11
Setting Items.....	11
Mode Select (MODE SELECT).....	11
Settings for the Exposure Function (EXPOSURE SET.).....	13
Settings for Other Functions (FUNCTION SET.).....	15
Camera Setup (CAMERA SETUP).....	19
Lens Setup (LENS SETUP).....	19
Mode Save (MODE SAVE).....	20
Defect Correction (BLEMISH COMPENSATION).....	20
Initialize (INITIALIZE).....	21
External Control Input Terminal.....	22
Connections.....	22
Setup.....	23
Specifications.....	24

## INTRODUCTION

Thank you for purchasing our product.

This device is a multifunctional, high performance CCD camera developed for high end security. The characteristics of this camera are as follows.

- (1) High Sensitivity  
The use of the high sensitivity 1/2"CCD realized the minimum scene illumination of 0.2 lux with a colour image.
- (2) Day and Night modes (DAY & NIGHT)  
Displays a high quality color picture during the day and a clear black and white picture at night.
- (3) Electronic sensitivity UP function (SENS UP)
- (4) ECLIPSER function (ECLIPSER)
- (5) On screen display function (OSD)
- (6) High definition
- (7) Small size

## CAUTIONS FOR OPERATION

### Area to use/store

This device is an indoor camera. Do not use it outside.

Do not expose the camera to extreme light sources (lighting and sunlight) regardless of use.

Avoid using and storing in the following locations.

- Extremely hot or cold locations (operating temperature -10° C to +50° C)
- High humidity or dusty locations
- In rainy locations or locations exposed to water
- Locations exposed to rigorous vibration
- Near TV and radio transmitting station with strong signals

### Care

- Wipe dirt off the casing with a soft dry cloth. For heavy soil, wipe off using a dry cloth after cleaning with a cloth with a small amount of mild detergent. Disconnect the power cord prior to cleaning.  
Do not use flammable liquids such as alcohol, benzene or thinner. This may damage the surface finish.
- Do not touch the surface of the CCD. If it gets dusty, wipe off with lens cleaning paper.

### Other

- White spots may appear on the screen due to normal characteristics of the imaging device. However, this is not a defect.  
White spots may also be noticeable when using the electronic sensing UP function (SENS UP). However, this is not abnormal.
- Colors may differ somewhat from actual colors depending on the lighting but this is not a defect.
- Highly light-intensive objects (such as lamps) may cause vertical stripes to appear on the screen. This is a normal characteristic of the imaging device and is not a defect.

## EXTERNAL CONTROLS AND CONNECTORS

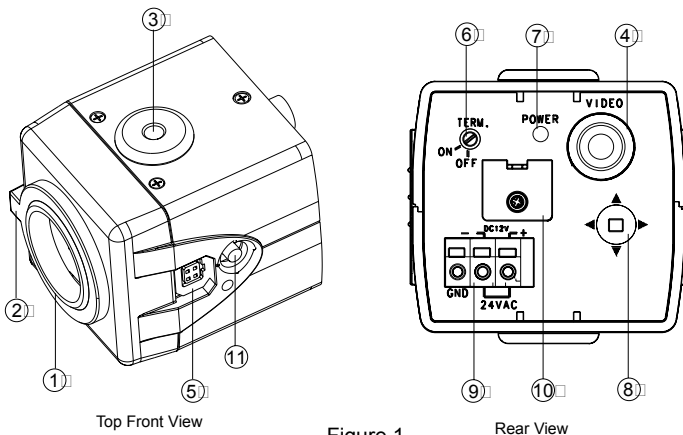

Figure 1

### ① Lens Mount

A suitable type CS mount lens may be attached. C mount lenses can be attached using a C/CS mount adapter.

### ② Back Focus Lock Screw

A ALLEN WRENCH can be inserted here to stabilize the lens mount using a screw to adjust the distance between the lens mounting surface and the imaging surface. Refer to "Lens: Back Focal Length Adjustment" for adjustment.

### ③ Camera Mounts

The camera can be mounted using either the top or bottom of the main body. Use 1/4 - 20 screw for mounting.

### ④ Video Output Connector

This is an output terminal for the video signal. (BNC type)

### ⑤ Lens Connector

4 Pin connector for an auto iris lens. Refer to "Lens: Electronic Connections" for wiring.

### ⑥ RS485 Terminal Switch

Use this when connecting an external device using the external control terminal of this device. ON: Terminal with 100  $\Omega$ . OFF: No terminal

### ⑦ Power Indicator

This lights up when powered on.

### ⑧ Setup Switch

This is a switch for the function settings. This is used when a menu is displayed and settings are determined.

For details, refer to "SETUP MENU: Settings Operation".

### ⑨ Power Input Terminal

This is the input terminal where power is supplied. This uses both 12 V DC and 24 V AC.

### ⑩ External Control Terminal

This can be used to connect an RS-485 I/O compatible terminal. It can also be used for an external control terminal for the DAY & NIGHT function. For details, refer to "External Control Input Terminal".

### ⑪ Iris Type Selector Switch

This switch is used to select the type of auto iris lens drive signal.

DC voltage drive: upward side. VIDEO signal control: downward side.

# LENS

## Electronic Connections

Refer to table 1 for the connector wiring diagram.

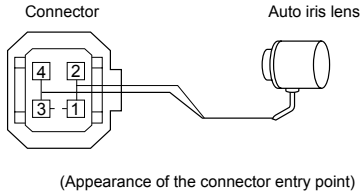

(Appearance of the connector entry point)

Figure 2

Connector Pin No.	Auto iris lens	
	DC voltage drive	VIDEO signal control
1	CONT. (-)	+9.5VDC (40mA max.)
2	CONT. (+)	+9.5VDC (40mA max.)
3	DRIVE (+)	AI-VIDEO
4	DRIVE (-)	GND

Note) Caution for using with VIDEO signal control lens

This device is not to correspond to brightness level adjustment on the body of VIDEO lens.

For adjustments of brightness, use "VIDEO LEVEL" on the menu. For the position of brightness level adjustment on the body, adjust it not to be 100% open or 100% close.

## Mechanical Connection

Lenses can be used, which have a thread length less than that specified below. Longer lenses may damage the imaging device.

Back focus is adjusted for CS mount type lenses when this device is shipped.

Use a C/CS mounting adaptor to attach a C mount lens.

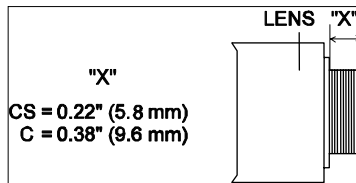

Figure 3

## Lens Adjustment

Adjust the mechanical iris lens.

Mount the lens on this device and adjust the lens before using.

Operating procedure

1. Move the cursor to "LENS SETUP" and press the switch. "LENS SETUP" screen is displayed.
2. Move the cursor to "LENS ADJUSTMENT" and press the switch.  
Move the cursor to "OK" and press the switch. Adjustment will be carried out.  
Carry out adjustment using a bright light source with no flicker.
3. The "LENS SETUP" screen will be displayed upon completion of adjustment.

Note) Repeat this adjustment procedure any time a lens is replaced.



## Back Focal Length Adjustment

The factory settings include back focus adjustment for a CS mount lens. However, adjustment may be required depending on the lens used. Use the back focus adjustment function to do this. Adhere to the following adjustment procedure.

### Operating procedure

1. Push the function settings switch up. (Jump function). The "LENS SETUP" screen is displayed (Figure 4-1). Move the cursor to "BACK FOCUS ADJ." and press the switch. When this screen is displayed, the lens is open.  
The back focus adjustment screen can also be reached from the "MAIN MENU-LENS SETUP" screen using the "Setting Operation" procedure.
2. Loosen the back focus lock screw using the ALLEN WRENCH. Adjust the lens mounting to fix the focus. Secure the lens mount with back focus lock screw.
3. Press the function settings switch to end the back focus adjustment.

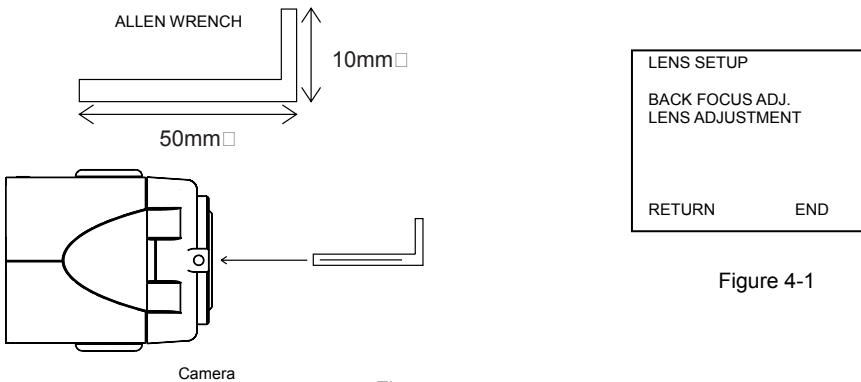

Figure 4-1

Figure 4

### Note)

Use the included ALLEN WRENCH for adjustment. Insert the long end of ALLEN WRENCH into the adjustment hole of the camera.

Rotate it in a clockwise approximately 15 degrees to fasten the lens mount.

If the back focus lock screw is too tight, the threads of the lens mount may be damaged.

### When using a zoom lens:

1. Objects further than 25 meters (70 feet) can be captured.
2. Set the focus to FAR.
3. Set the zoom to wide angle.
4. Complete the above procedures 1-3.
5. Set the zoom to telephoto.
6. Adjust the focus.

# POWER CONNECTION

Use 24 V AC / 12 V DC for this device.



**Warning:** Be careful not to short circuit the power cord when connecting it to the device.

## AC Power Connection

Use 24 V AC (20.4 - 27.6 V AC) 50 Hz / 60 Hz to power the device. Refer to figure 5 as to connecting the power.

Peel back the casing of the power cord about 10 mm and insert the twisted wire directly into the terminal.

If the power cord can not be inserted, try pressing the button on the terminal and inserting again.



**Caution**

Pull on the power cord and make sure that it is connected. Make sure the wire of power cord is not exposed outside of the terminal. Use class 2 power supply. Connect the GND line to GND terminal.



**Caution**

270 mA (24 V AC) of current is used by this device. The capacity to supply multiple connections is required when multiple devices are connected to one power source.

## DC Power Connection

Use 12 V DC (10.2 – 13.8 V DC). Refer to figure 6 as to connecting the power.

When a fuse is necessary, connect a slow blow fuse within 10 cm of the power terminal (+ terminal side).



**Caution**

Pay attention to the power polarity. 390 mA of current is required for each device. Be careful with following items when choosing and connecting the power cord.

- 1) Allowable current for the power cord
- 2) Power cord size and length

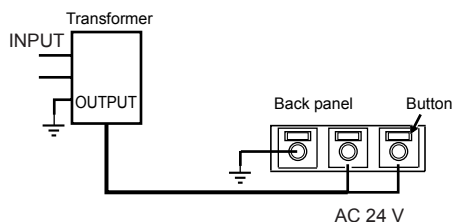

Figure 5

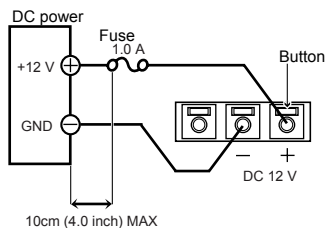
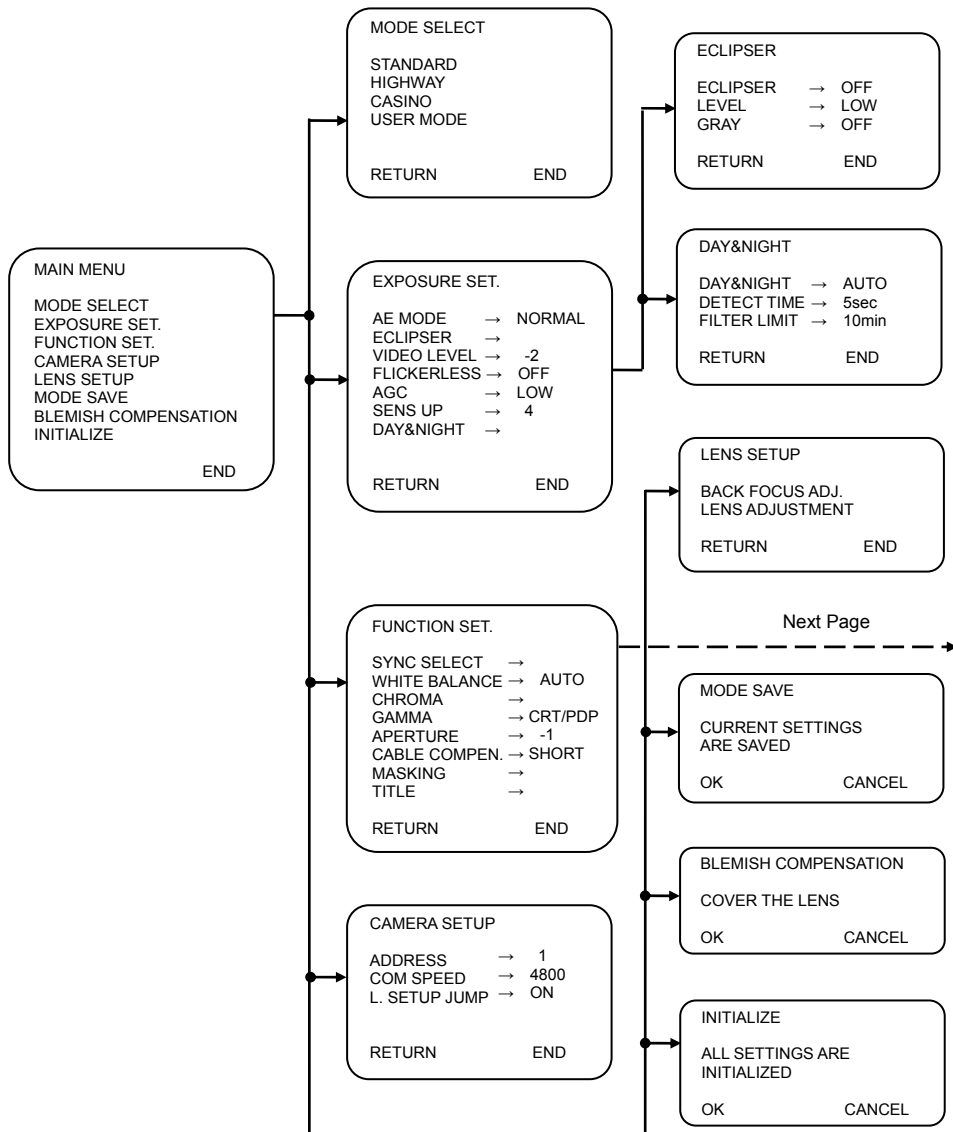
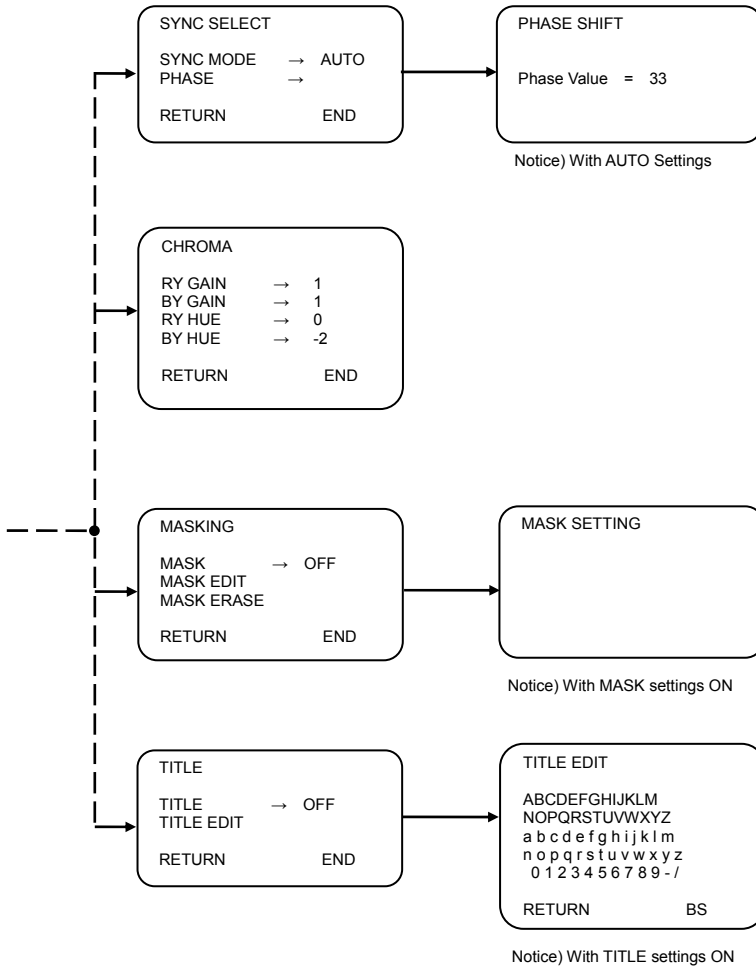

Figure 6

# SETUP MENU

This device is equipped with an OSD (On Screen Display) feature and various functions can be set using this camera's monitor screen.  
A list of settings menu is as follows.





## Settings Operation

This device is equipped with an OSD (On Screen Display) feature. Operate as follows to change settings using the menu.

1. Press and hold the function setting switch on the back panel for about two seconds. (Figure 1⑧).
2. The settings screen shown in figure 7-1 is displayed.
3. Move the cursor to the item that you want to change using the switch. The selected menu is displayed.
4. Adjust the setting value of the item you want to change.
5. Move the cursor to "END" to finish the settings and press the switch.  
Move the cursor to "RETURN" to return to the previous item and press the switch.

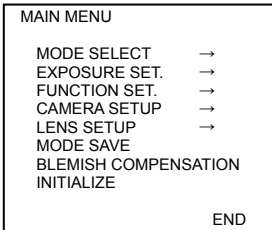

Figure 7-1 MAIN MENU

Note)

- If the menu is not operated for one minute, the menu will automatically turn off.
- The setting for each item is saved when "RETURN" and "END" are selected.
- \* is displayed for the items limited based on the setting of a function.

## Setting Items

### (1) Mode Select (MODE SELECT)

Camera is operated using the preset settings by selecting the various modes. It is possible for the user to register user determined settings (USER MODE). Refer to "MODE SAVE" for the setting procedure for "USER MODE".

The following modes can be selected.

STANDARD  
HIGHWAY  
CASINO  
USER MODE

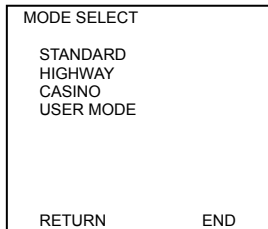

Figure 7-2 MODE SELECT menu

The details of each of the mode settings are as follows.

### STANDARD

EXPOSURE SET.	
AE MODE	→ NORMAL
ECLIPSER	→ ( OFF )
(LEVEL)	→ ( LOW )
(GRAY)	→ ( OFF )
VIDEO LEVEL	→ -2
FLICKERLESS	→ OFF
AGC	→ LOW
SENS UP	→ 4
DAY&NIGHT	→ (COLOR)
(DETECT TIME)	→ ( 5sec )
(FILTER LIMIT)	→ ( OFF )
RETURN	END

FUNCTION SET.	
SYNC SELECT	→ ( AUTO )
WHITE BALANCE	→ AUTO
CHROMA	→
GAMMA	→ CRT/PDP
APERTURE	→ -1
CABLE COMPEN.	→ SHORT
MASKING	→
TITLE	→
RETURN	END

Figure 7-3 STANDARD settings

### HIGHWAY

EXPOSURE SET.	
AE MODE	→ SP
ECLIPSER	→ ( OFF )
(LEVEL)	→ ( LOW )
(GRAY)	→ ( OFF )
VIDEO LEVEL	→ -2
SHUTTER MAX.	→ 1/50000
AGC	→ LOW
SENS UP	→ OFF
DAY&NIGHT	→ ( AUTO )
(DETECT TIME)	→ ( 5sec )
(FILTER LIMIT)	→ ( 10min )
RETURN	END

FUNCTION SET.	
SYNC SELECT	→ ( AUTO )
WHITE BALANCE	→ AUTO
CHROMA	→
GAMMA	→ CRT/PDP
APERTURE	→ -1
CABLE COMPEN.	→ SHORT
MASKING	→
TITLE	→
RETURN	END

Figure 7-4 HIGHWAY settings

### CASINO

EXPOSURE SET.	
AE MODE	→ NORMAL
ECLIPSER	→ ( OFF )
(LEVEL)	→ ( LOW )
(GRAY)	→ ( OFF )
VIDEO LEVEL	→ -2
FLICKERLESS	→ OFF
AGC	→ LOW
SENS UP	→ 4
DAY&NIGHT	→ (COLOR)
(DETECT TIME)	→ ( 5sec )
(FILTER LIMIT)	→ ( OFF )
RETURN	END

FUNCTION SET.	
SYNC SELECT	→ ( INT )
WHITE BALANCE	→ INDOOR
CHROMA	→
GAMMA	→ LCD
APERTURE	→ -1
CABLE COMPEN.	→ SHORT
MASKING	→
TITLE	→
RETURN	END

Figure 7-5 CASINO settings

## (2) Settings for the Exposure Function (EXPOSURE SET.)

This is a menu to adjust the camera exposure. Adjustable items vary with setting the "AE MODE".

EXPOSURE SET.		ECLIPSER		DAY&NIGHT	
AE MODE	→ NORMAL	ECLIPSER	→ OFF	DAY&NIGHT	→ AUTO
ECLIPSER	→	LEVEL	→ LOW	DETECT TIME	→ 5sec
VIDEO LEVEL	→ -2	GRAY	→ OFF	FILTER LIMIT	→ 10min
FLICKERLESS	→ OFF				
AGC	→ LOW				
SENS UP	→ 4				
DAY&NIGHT	→				
RETURN	END	RETURN	END	RETURN	END

Figure 8-1 EXPOSURE SET. menu

### AE MODE

Sets the exposure mode.

The mode can be changed to NORMAL → ESC → MANUAL → SP → AP, in this order.

**NORMAL** : This mode is controlled by mechanical iris. "FLICKERLESS" can be set.

**ESC** : This mode is controlled by electronic shutter speed.

**MANUAL** : Shutter speed is manually set. Set with "SHUTTER SPEED".

**SP,AP** : Switches automatically between mechanical iris and electronic shutter to control the exposure time. "SP" is shutter priority mode. "AP" is aperture priority mode.

When "SP" is selected, "SHUTTER MAX." can be set.

When "AP" is selected, "SHUTTER MIN." can be set.

### ECLIPSER

This function allows fine picture correction to prevent the subject from being extremely dark due to strong backlight.

**ECLIPSER** : This sets "ECLIPSER" function ON/OFF

**LEVEL** : The effect of eclipser function can be set. LOW, MIDDLE and HIGH can be selected.

**GRAY** : The light background signal is converted into a gray level video signal.

OFF, LOW and HIGH can be selected.

### VIDEO LEVEL

Adjusts the brightness of the screen. Setting values: -5 to 5

Note) This can be adjusted using "AE MODE" in addition to "ECLIPSER".

### FLICKERLESS

When "AE MODE" is set to "NORMAL", the flickerless function can be set ON/OFF.

If ON is selected, the shutter speed is fixed at 1/100 s (NTSC) or 1/120 s (PAL).

### SHUTTER SPEED

The shutter speed can be set when the "AE MODE" is set to "MANUAL".

Setting values: 1/60(NTSC), 1/50(PAL), 1/100(NTSC), 1/120(PAL), 1/250, 1/500, 1/1000, 1/2000, 1/4000, 1/10000, 1/20000, 1/50000

### SHUTTER MAX.

When "AE MODE" is set to "SP", the maximum value of shutter speed can be set.

Setting values: 1/500, 1/1000, 1/2000, 1/5000, 1/10000, 1/20000, 1/50000

### SHUTTER MIN.

When "AE MODE" is set to "AP", the minimum value of shutter speed can be set.

Setting values: 1/60(NTSC), 1/50(PAL), 1/100(NTSC), 1/120(PAL), 1/200

### AGC

Gain is automatically adjusted when AGC is HIGH and LOW based on the brightness of the object. AGC OFF locks the gain at a minimum.

### SENS UP

The brightness is increased by lengthening the CCD imaging time over several fields.

Setting values: OFF, 2, 4, 6, 8, 10, 20, 40 (The setting indicates the maximum imaging time. The imaging time will change automatically based on the brightness of the object.)

Note)

- This item can not be selected when the selected "AE MODE" is "MANUAL". It is automatically switched to OFF.
- When the magnification of "SENS UP" is increased, the screen may look rough, washed out, or have white spots. This is not a defect.

### DAY & NIGHT

This is used to switch between day (color) and night (black/white) settings.

AUTO: This switches between color mode and black/white mode automatically based on the brightness of the screen.

COLOR: Selects color mode.

BW: Selects black/white mode.

EXT.: This switches modes based on an external control signal. For details, refer to "External Control Input Terminal".

Note)

- If "AGC" is set to "OFF", then "DAY&NIGHT" can not be set to "AUTO" or "EXT".
- If "AGC" is set to "OFF", this will be forcibly set to "COLOR or BW" when "DAY&NIGHT" is set to "AUTO".
- The mode can switch automatically based on the brightness of the object when using the "AUTO" settings, however, it may not switch depending on the lighting conditions and angle of view.
- Hunting may occur if using near infrared lighting at night. This device includes a function to stop filtering when hunting occurred as a countermeasure for this problem. You can set the stopping time with the "FILTER LIMIT" item to use this function. Selecting "EXT" in switch mode from external input is recommended to ensure that it switches.

**DETECT TIME** (Use the "AUTO" and "EXT" settings for "DAY&NIGHT".)

The detection time for DAY&NIGHT can be set.

If the brightness level change continues for longer than the time set in this item, the mode will switch.

5 sec, 30 sec

**FILTER LIMIT** (Use the "AUTO" and "EXT" settings for "DAY&NIGHT".)

The time to stop filtering when hunting occurs during DAY & NIGHT operation can be set.

OFF, 10 min, 30 min

Note) \* is displayed before the "FILTER LIMIT" during the operation of this function.



### (3) Settings for Other Functions (FUNCTION SET.)

This is a menu to set various functions other than exposure.

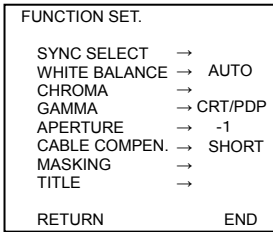

Figure 9-1 FUNCTION SET. menu

#### (3-1) SYNC SELECT

The synchronization can be set.

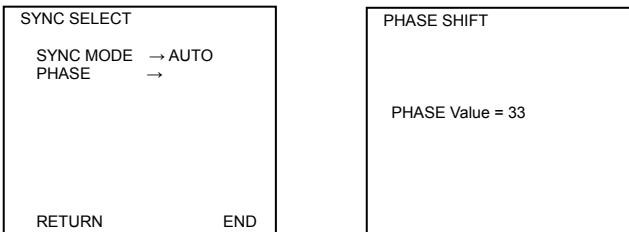

Figure 9-2 SYNC SELECT menu

#### SYNC MODE

This selects the sync system.

**AUTO:** This operates with LineLock for the AC power and operates with Internal for DC power.

**INT:** This always operates using internal sync.

#### PHASE

This adjusts the vertical sync phase during LineLock operation.

Method for adjustment

1. Set "SYNC MODE" to "AUTO".
2. Move the cursor to "PHASE" and press the switch to display the "PHASE SHIFT" screen.
3. The vertical sync phase can be adjusted by moving the switch up or down from "PHASE SHIFT" screen. Refer to figure 9-3.

Note) The phase of each camera is set to same phase at the factory. Usually, the phase doesn't need readjustment.

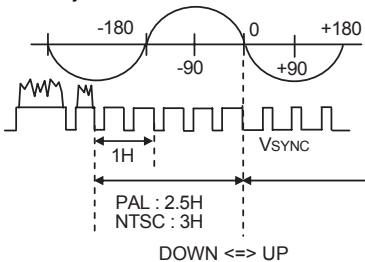

Adjustable Range

0 to 52 (NTSC)

0 to 62 (PAL)

Figure 9-3 PHASE SHIFT

### (3-2) WHITE BALANCE

#### WHITE BALANCE

The mode for white balance can be selected.

**AUTO:** White balance is adjusted automatically.

**HOLD:** The white balance used right before changing to this mode is maintained. This is suitable for imaging in a location where lighting doesn't change. Refer to the following setting method.

White balance maintained using the "HOLD" mode is lost if it is switched to the "AUTO" mode.

Method for the HOLD setting

1. "WHITE BALANCE" is set to "AUTO" in the condition that the object is captured.
2. "WHITE BALANCE" is switched "AUTO→HOLD".  
In this process, the white balance is maintained.

**INDOOR** : Fixed white balance for lighting of approximately 2800 K.

**OUTDOOR** : Fixed white balance for lighting of approximately 6000 K.

### (3-3) CHROMA

The gain and hue of the chroma signal can be adjusted.

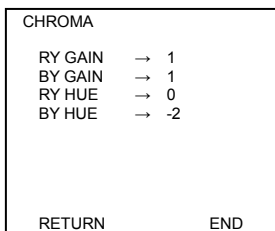

Figure 9-4 CHROMA menu

#### RY GAIN

This adjusts the gain of chroma signal. Adjustment range -5 ~ 5

#### BY GAIN

This adjusts the gain of chroma signal. Adjustment range -5 ~ 5

#### RY HUE

This adjusts the hue of chroma signal. Adjustment range -5 ~ 5

#### BY HUE

This adjusts the hue of chroma signal. Adjustment range -5 ~ 5

### (3-4) GAMMA

#### GAMMA

This selects the gamma setting.

CRTP/PDP (approx. 0.6), LCD (approx. 0.45), OFF (approx. 1.0)

### (3-5) APERTURE

#### APERTURE

This sets edge enhancement. It sharpens the image in the "+" direction and softens the image in the "-" direction.

Settings values; -5 to 5

### (3-6) CABLE COMPENSATION

#### CABLE COMPEN.

Cable compensation function can be set. This function can be used to reduce the degradation of a video signal by wiring. By wiring length of a cable, change setting.

SHORT: Wiring length to 100 meters

MIDDLE: Wiring length from 100 to 300 meters

LONG: Wiring length from 300 to 500 meters

Note) With above wiring length used 5C-2V

### (3-7) MASKING

Sets the mask setting for the screen.

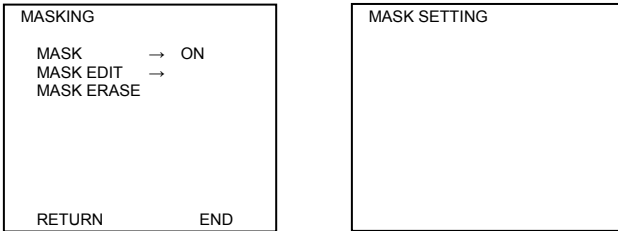

Figure 9-5 MASKING menu

#### MASK

This sets the MASK display ON/OFF.

#### MASK EDIT

This edits the created mask. In total, up to 8 masks can be set.

Method to create a mask

1. Set "MASK" to "ON".
2. Move the cursor to "MASK EDIT" and press the switch to display the "PRIVACY MASK SETTING" screen.
3. An arrow is displayed on the screen. Determine the position of the mask to be created using this arrow.

First, move the arrow to upper left of mask to be created and select the position with the switch.

Move the arrow next to the lower right, and mask will be created by selecting the position with the switch.

#### MASK ERASE

This erases the created mask.

Method to erase a mask

1. Move the cursor to "MASK ERASE".
2. Press the switch in this position to erase the mask.

Note) If multiple masks have been created, the masks are erased in the opposite order the masks were created.

### (3-8) TITLE

This creates text and sets it to display on the screen.

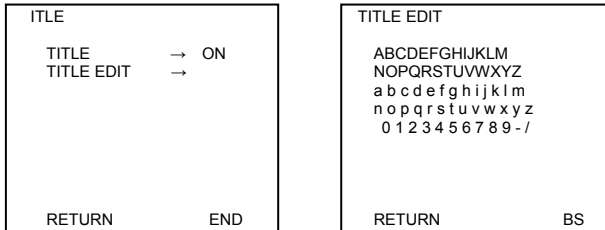

Figure 9-6 TITLE menu

### TITLE

This sets the display of text ON/OFF.

### TITLE EDIT

This edits the text to be displayed. Up to 16 characters can be displayed.

Method to create a title

1. Set "TITLE" to "ON".
2. Move the cursor to "TITLE EDIT" and press the switch to display the "TITLE EDIT" screen.
3. Move the cursor to the text you want to display and press the switch. The selected text is displayed in the editing area.
4. Repeat the above steps until editing is complete.
5. Move the cursor to "BS" and press the switch to erase one character.

#### (4) Camera Setup (CAMERA SETUP)

This device is equipped with an external control input terminal (RS-485) and settings for each function can be changed from an external unit.

For details, refer to “*External Control Input Terminal*”.

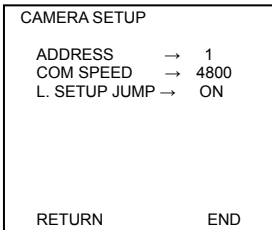

Figure 10 CAMERA SETUP menu

#### ADDRESS

This sets numbers to identify multiple cameras. Up to 30 cameras can be connected.

Note) If these numbers overlap in the system, it won't operate properly.

#### COM SPEED

This sets the communication speed with the external unit.

2400, 4800, 9600 and 19200 can be selected.

#### L. SETUP JUMP

This switches the jump function to jump to “LENS SETUP” screen.

ON: Valid, OFF: Invalid

#### (5) Lens Setup (LENS SETUP)

This adjusts the back focus and reference voltage for the mechanical iris.

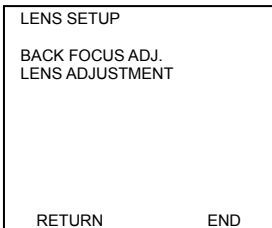

Figure 11 LENS SETUP menu

#### BACK FOCUS ADJ.

For details, refer to “*Lens: Back Focal Length Adjustment*”

Optical back focus adjustment and lens focus adjustment are possible using this function.

#### LENS ADJUSTMENT

For details, refer to “*Lens: Lens Adjustment*”.

(6) Mode Save (MODE SAVE)

This saves the current settings.

It loads the saved settings by selecting "USER MODE" from "MODE SELECT".

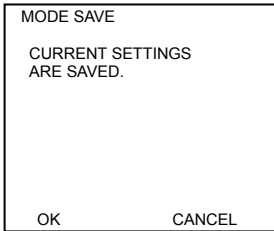

Figure 12 MODE SAVE menu

Operating procedure

1. After changing the settings, move the cursor to "MODE SAVE" and press the switch to display the "MODE SAVE" screen.
2. Move the cursor to "OK" and press the switch to save the settings.
3. When saving is completed, it automatically returns to the "MAIN MENU".

(7) Defect Correction (BLEMISH COMPENSATION)

This detects and corrects white spots.

This function can be used to maintain the quality level.

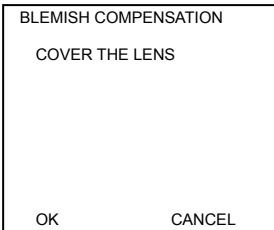

Figure 13 BLEMISH COMPENSATION menu

Operating procedure

1. Cover the lens to prevent light from entering. Move the cursor to "BLEMISH COMPENSATION" from the "MAIN MENU" and press the switch to display the "BLEMISH COMPENSATION" screen.
2. Move the cursor to "OK" and press the switch to run the correction.
3. This automatically returns to the "MAIN MENU" when the correction is completed.

Note)

- White spots may not be corrected entirely by this function.
- White spots may become more noticeable when the SENS UP function is used. This is not a defect.
- Light can not be blocked completely using the mechanical iris focusing mechanism. Do this in dark conditions as much as possible or use the lens cap to block the light.

### (8) Initialize (INITIALIZE)

This returns all settings to the initial factory settings.

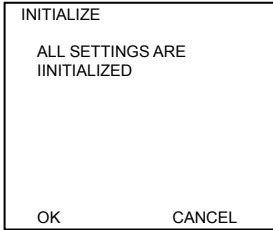

Figure 14 INITIALIZE menu

#### Operating procedure

1. Move the cursor to "INITIALIZE" and press the switch to display the "INITIALIZE" screen.
2. Move the cursor to "OK" and press the switch to run initialization.
3. This automatically returns to the "MAIN MENU" when initialization is complete.

Note) The following settings won't be reset with this initialization.

- Setting value of "ADDRESS" and "COM SPEED" from the "CAMERA SETUP" menu
- "PHASE" phase adjustment value of "SYNC SELECT" from "FUNCTION SET." menu
- BLEMISH COMPENSATION value after running the "BLEMISH COMPENSATION"

Setting details are shown when initialize is running.

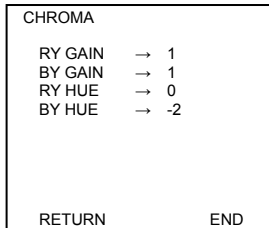
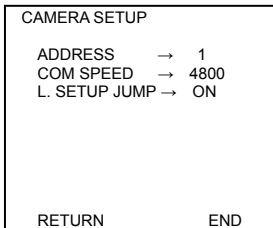
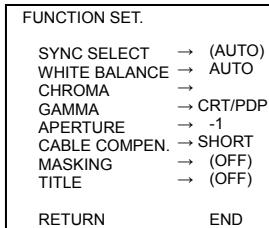
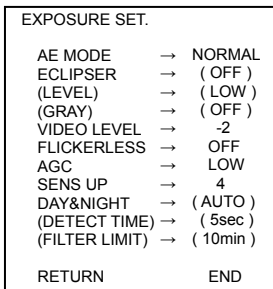

Figure 15 Setting details for INITIALIZE

# External Control Input Terminal

This device is equipped with an external control signal terminal for remote operation.

## Connections

Refer following figure for connector wiring.

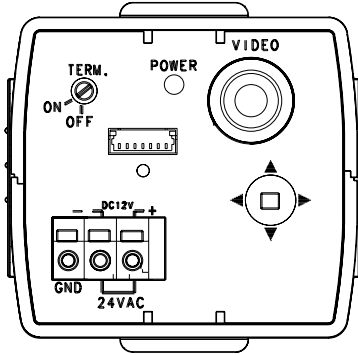
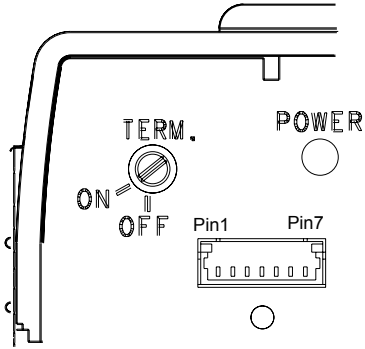

Figure 16



Enlarged

Pin No.	Description
1	A (+)
2	B (-)
3	GND
4	A (+)
5	B (-)
6	GND
7	DAY&NIGHT external control terminal

Connect the supplied cable to the connector when this terminal is used and use a shielded twisted pair cable as an extension cable. Use adequate insulation coating to avoid short circuiting the connection area.

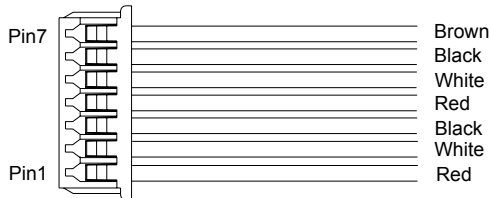

Figure 17

Note)

- Disconnect the power for connection.
- Use the same terminating resistance value for impedance of the cable used. (100 Ω)



## Setup

Use the following procedure to set up the system using this terminal.

Setting procedure

1. Connect the cables to each camera.
2. Turn the camera terminal SW which is set on terminal to ON. Set other cameras to OFF. (figure 1 ©)
3. Set the address for each camera using "CAMERA SETUP".  
Do not use the same address.
4. Set the communication speed using "CAMERA SETUP". Set the same value for each camera.

Use the following procedure to control the DAY&NIGHT function externally.

Setting procedure

1. Set "DAY&NIGHT" to "EXT." in "FUNCTION SET."
2. Change the DAY&NIGHT function mode by inputting the control signal.  
H input or open : Operates in AUTO mode  
L input or short: Operates in black/white mode  
(This terminal is pulled up inside the camera. There is no ability to drive an external device.)

<Ratings and Electrical Characteristics>

Rating input voltage  $V_{IN}$  : -0.3 ~ 3.3 V

High level input voltage  $V_{IH}$  : Min.3.0 V

Low level input voltage  $V_{IL}$  : Max.0.3 V

Use within the above values.

# Specifications

Model Name	CG-641	
TV system	NTSC	PAL
Power supply	24 V AC $\pm 15\%$ (50 Hz / 60 Hz) / 12 V DC $\pm 15\%$	
Power consumption	270 mA (24 V AC) / 390 mA (12 V DC)	
Imaging device	1/2-type interline transfer CCD	
Effective pixels	Approx. 380,000 pixels	Approx. 440,000 pixels
Sync. system	Internal (INT.) / Line Lock (L.L.)	
S/N ratio	50 dB or more (AGC off, weighted)	
Video output	1 V (p-p) / 75 $\Omega$	
Horizontal resolution	520 TV Lines (Color) 550 TV Lines (BW)	
Minimum object illumination (F1.2 50IRE)	AGC: HIGH	0.2 lx (Color) 0.01 lx (B/W) 0.005 lx (SENSup 40 times Color)
	AGC: LOW	0.4 lx (Color) 0.02 lx (B/W)
Function	Electronic sensitivity UP function DAY&NIGHT function ECLIPSER function OSD function Blemish compensation function Cable compensation function	White balance function AGC function (HIGH/LOW/OFF) SYNC selectable (INT/ AUTO) Flickerless function Aperture function Back focus adjustment function
Lens mount	CS mount (flange back adjustable)	
Auto iris lens	DC voltage drive and VIDEO signal control lens	
Camera mount	1/4"-20 UNC, top and bottom	
Weight	0.2 kg	
External dimensions	55 (W) $\times$ 50 (H) $\times$ 62 (D) mm	
Ambient temperature	-10°C~+50°C (0°C~+40°C; Performance guarantee)	
Input / Output terminals	(1) Video signal output (BNC) (2) Auto iris lens output (4-pin) (3) Connector for supply voltage (3-pin) (4) RS485 I/O connector (7-pin) *Including external control terminal for DAY&NIGHT	
Switches	Switch for function settings RS485 terminal ON/OFF switch Iris type selector switch	
Accessories	Connector for auto iris lens ALLEN WRENCH Instruction manual (simplified version) CD-ROM (Instruction manual) Connector for external control terminal	1 1 1 1 1

We reserve the right to modify some specifications of the specifications listed here in order to maintain and improve device performance.



## **FUJITSU GENERAL LIMITED**

1116, Suenaga,  
Takatsu-ku,  
Kawasaki 213-8502,  
Japan