

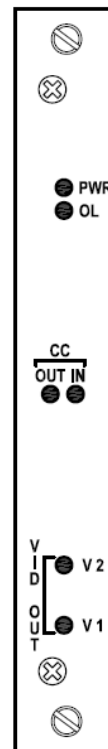

All Digital Fiber Optic Manufacturing Specialists

# Installation and Operation Manual

## FT210CB Series

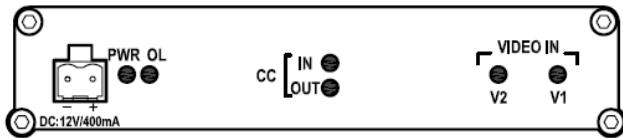

## 10-bit Digital Series

2-ch Video with 1 Bi-directional Contact Closure

Fiber Optic Converter

## Models covered in this manual

### Standalone Units

#### Single-Mode Transmitters

FT210CB-SSTSA  
FT210CB-SSTLSA

#### Single-Mode Receivers

FT210CB-SSRSA  
FT210CB-SSRLSA

#### Multi-Mode Transmitter

FT210CB-SMTSA

#### Multi-Mode Receiver

FT210CB-SMRSA

### Card Modules

#### Single-Mode Transmitters

FT210CB-SST  
FT210CB-SSTL

#### Single-Mode Receivers

FT210CB-SSR  
FT210CB-SSRL

#### Multi-Mode Transmitter

FT210CB-SMT

#### Multi-Mode Receiver

FT210CB-SMR

### **Remark:**

If the optical connector is FC type, the suffix in the model number will be “-*FXX*”. Eg.  
FT210CB-FST

## Table of Contents

(1)	SAFETY INSTRUCTIONS.....	3
(2)	PRODUCT OVERVIEW .....	4
	2.1 Introduction.....	4
	2.2 Models selection table .....	5
(3)	INSTALLATION .....	6
	3.1 General .....	6
	3.2 Standalone unit installation.....	6
	3.3 Card module installation .....	7
(4)	CABLE CONNECTIONS & SETUP PROCEDURES.....	7
	4.1 System cable connections.....	7
	4.2 Contact Closure (CC) connections .....	9
	4.3 Ground connection .....	10
(5)	OPERATIONAL GUIDES.....	11
	5.1 FT210CB Series Transmitter .....	11
	5.2 FT210CB Series Receiver.....	11
(6)	SPECIFICATIONS.....	12
(7)	DRAWINGS.....	13
(8)	WARRANTY INFORMATION .....	13
(9)	CONTACT INFORMATION.....	13

## (1) Safety Instructions

**Please be familiar with all information in this manual prior to installation and operation.**

**Note 1:** The products described contain a Class 1 laser or LED fiber optic emitter. The following safety precautions apply.

**Warning:** Do not disconnect the fiber optic connector while the unit is powered up. Exposure to Class I invisible optical radiation is possible when the internal fiber optic connector is disconnected while the unit is powered up.

**Caution:** Any access to the controls, adjustments, or performing operations, which are other than those specified may result in hazardous radiation exposure. Permanent eye damage or other bodily injuries may be resulted from such exposure even for only seconds.

**Note 2:** This assembly contains parts sensitive to damage by electrostatic discharge (ESD). ESD precautionary procedures should be applied in the course of touching, removing or inserting parts or assemblies.

## **(2) Product Overview**

### **2.1 Introduction**

The FT210CB Series products comprise of either single-mode or multi-mode fiber optic transmitters and receivers for the optical transmission of TWO forward (Tx → Rx) video and ONE bi-directional (Tx ↔ Rx) contact closure signal on one fiber. The products work at wavelengths of 1310nm and 1550nm with either a 9/125um or 62.5/125um fiber for single-mode or multi-mode transmission respectively.

A non-compressed 10-bit digital video transmission scheme is implemented which supports video in NTSC, PAL and SECAM formats.

Bi-directional transmission of Contact Closure (CC) status is also supported. The CC input can be a Dry contact or a TTL logic input. Normally Open (NO) or Normally Close (NC) Contact selectable output is provided for a maximum current of 1000mA at 110VDC/125VAC.

For single-mode transmission, we also offer specifically designed products for long-haul transmissions up to 60km. These models include the letter “L” in the suffix, e.g. FT210CB-SSTL for Tx, FT210CB-SSRL for Rx, etc.

The FT210CB Series units are available as standalone units, which can be mounted horizontally or vertically wall-mounted on any fixture. The standalone unit comes with an external power supply FT-PA/12V, which can be powered by local 110/220V power.

The FT210CB Series units are also available as plug-in card modules installed in a 19” rack-mount chassis. Each plug-in card occupies one slot in the rack-mount chassis. The rack mount chassis has to be ordered separately, and comes with its own power supply for powering the installed card modules.

## 2.2 Models selection table

Type	Mode	Models <sup>1</sup>	Descriptions	Installation requirements	Remarks
Standalone Units	Single-Mode	FT210CB-SSTSA	Single-mode 2-Ch. Video Transmitter & 1 CC Transceiver Standalone Unit	Horizontally or vertically wall-mounted Standalone unit	FT-PA/12V external power supply is included for the Standalone unit <sup>2</sup>
		FT210CB-SSTLSA	Single-mode Long-haul 2-Ch. Video Transmitter & 1 CC Transceiver Standalone Unit		
		FT210CB-SSRSA	Single-mode 2-Ch. Video Receiver & 1 CC Transceiver Standalone Unit		
		FT210CB-SSRLSA	Single-mode Long-haul 2-Ch. Video Receiver & 1 CC Transceiver Standalone Unit		
	Multi-Mode	FT210CB-SMTSA	Multi-mode 2-Ch. Video Transmitter & 1 CC Transceiver Standalone Unit		
		FT210CB-SMRSA	Multi-mode 2-Ch. Video Receiver & 1 CC Transceiver Standalone Unit		
Card Modules	Single-Mode	FT210CB-SST	Single-mode 2-Ch. Video Transmitter & 1 CC Transceiver Card Module	Housed in FT-C18 chassis <sup>3</sup>	FT-C18 chassis has to be ordered separately
		FT210CB-SSTL	Single-mode Long-haul 2-Ch. Video Transmitter & 1 CC Transceiver Card Module		
		FT210CB-SSR	Single-mode 2-Ch. Video Receiver & 1 CC Transceiver Card Module		
		FT210CB-SSRL	Single-mode Long-haul 2-Ch. Video Receiver & 1 CC Transceiver Card Module		
	Multi-Mode	FT210CB-SMT	Multi-mode 2-Ch. Video Transmitter & 1 CC Transceiver Card Module		
		FT210CB-SMR	Multi-mode 2-Ch. Video Receiver & 1 CC Transceiver Card Module		

<sup>1</sup> If the optical connector is FC type, the suffix in the model number will be “-FXX”. Eg. FT210CB-FST

<sup>2</sup> FT-PA/12V works under 100 -240VAC, 50/60Hz power supply

<sup>3</sup> Refer to FT-C18 product manual for specifications

### (3) Installation

#### 3.1 General

All OT Systems products are thoroughly inspected, tested and securely packaged before delivery to ensure a stable, intact and trouble-free service. Please check the equipment upon receipt for any visible damage which may have been caused during shipping.

The FT210CB Series standalone units (Fig. 3.1) can be either horizontally or vertically wall-mounted, or mounted on any fixture. The Standalone unit works with an external power supply FT-PA/12V powered by local 110/220V power.

The FT210CB Series card modules are housed inside the FT-C18 rack-mount chassis (Fig. 3.2) with an included power supply unit. The whole chassis is powered by local 110/220V power. FT-C18 is a standard 19" (483mm) rack-mount chassis which occupies 4 rack units (177.8mm) in height. Each FT210CB card module occupies one slot and a total of 18 cards can be housed inside the chassis.



Fig. 3.1 Standalone unit



Fig. 3.2 FT-C18 chassis

#### 3.2 Standalone unit installation

- a) Mount the standalone unit onto a fixture, (either on the wall or on a flat surface) with four screws through the holes on the mounting frame to secure it in position.
- b) The provided power supply should also be mounted on the same fixture or in the proximity for connection of the supply cables to the unit, provided that an AC power supply socket is nearby for powering the adaptor.
- c) Connect all the signal inputs and outputs at the back of the unit with appropriate cables: fiber optic cable for optical link, BNC cable for video input/output (Tx/Rx), and UTP cable for contact closure input/output (Tx/Rx).
- d) Once the unit is powered up, check that the red POWER LED on the unit is lit. If not, check the power supply cable connections between the unit and the power supply socket.
- e) With all the signals available at the input and output ports, check the status of LEDs located on the unit. With correct status of each LED, installation is now completed [for LEDs status, see **Operational Guides** on this manual's section (5)].

### 3.3 Card module installation

- Insert the card module into the FT-C18 chassis along the top and bottom card guides of an empty slot and push the card into the multi-pin socket at the rear firmly. Secure with the provided thumb screws.
- Repeat the above procedure for all the rest card modules. Unused slots must be covered with blank panels provided.
- Connect all the signal inputs and outputs at the back of the unit with appropriate cables: fiber optic cable for optical link, BNC cable for video input/output (Tx/Rx), and UTP cable for contact closure input/output (Tx/Rx).
- Once the chassis is powered up, check that the red POWER LED on the front and back panels of the card modules are lit. If not, check the power supply cable connections between the chassis and the power supply socket. For failures of individual card's POWER LEDs, check the corresponding card modules, whether they have been inserted properly.
- With all the signals available at the input and output ports, check the status of LEDs located on the unit. With correct status of each LED, installation is now completed [for LEDs status, see **Operational Guides** on this manual's section (5)].

## (4) Cable Connections & Setup Procedures

### 4.1 System cable connections

Signal Type	Cable Type	Connector
Optical	Single-mode or Multi-mode fiber	ST (or FC) Connector
Video	Coaxial Video Cable	BNC Connector
Contact closure	Twisted-pair Cable	Screw Terminal Block

#### Typical System Cable Connections Diagrams:

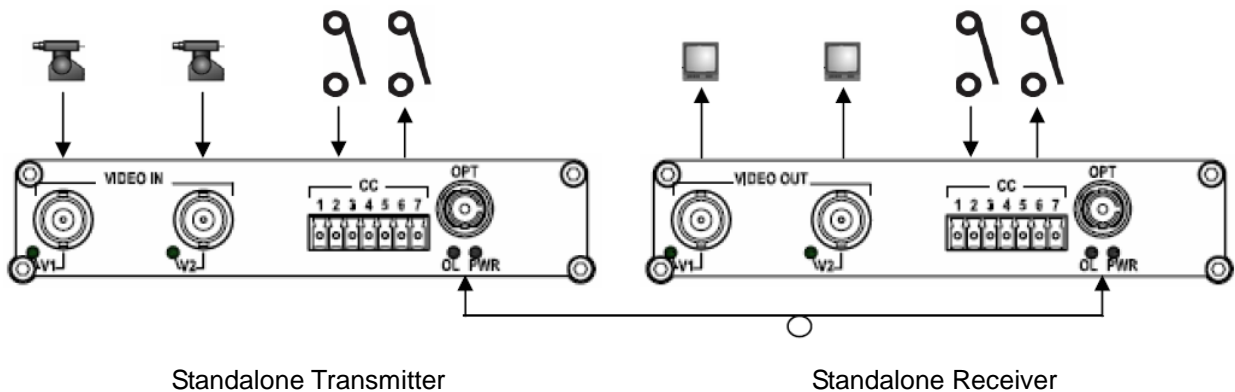
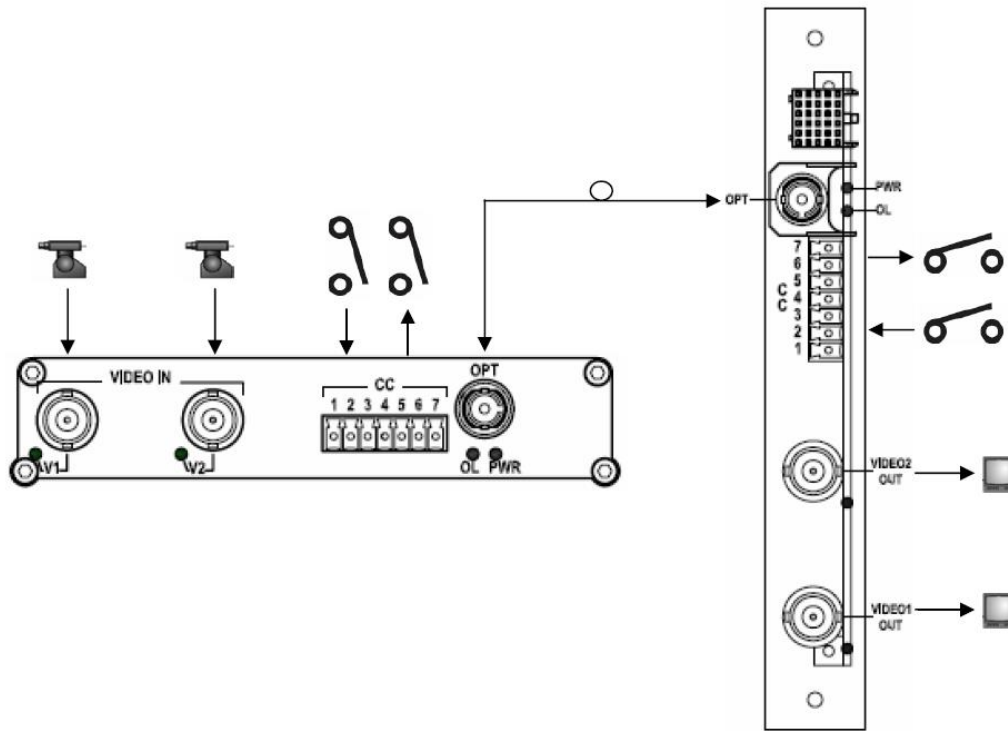

Fig 4.1 Standalone unit to Standalone unit connection diagram





Standalone Transmitter

Card Module Receiver

Fig 4.2 Standalone unit to Card Module connection diagram

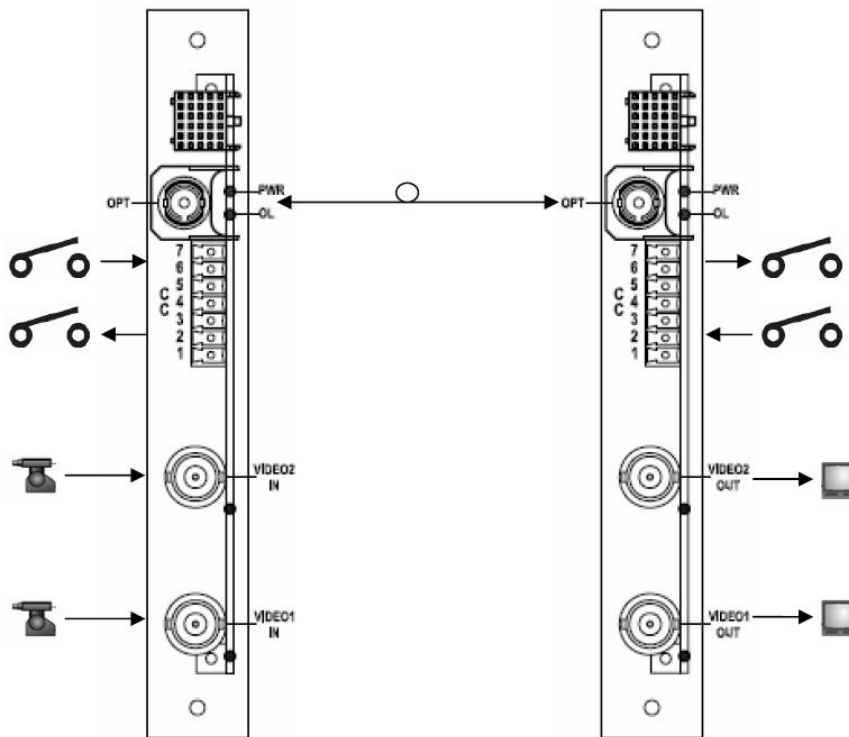

Card Module Transmitter

Card Module Receiver

Fig 4.3 Card Module to Card Module connection diagram

## 4.2 Contact Closure (CC) connections

For Contact closure input and output connections, please note the following pin assignment:

Pin Assignment (Screw Terminal Block)		1	2	3	4	5	6	7
		Data format						
Input	Contact closure / TTL	Input (Hi)	Input (Low /COM)	N/A	N/A	N/A	N/A	N/A
		Output (Hi)	Output (Low /COM)	N/A	N/A	N/A	N/A	N/A
Output	Normally Close (NC)	N/A	N/A	Output (Hi)	Output (Low /COM)	N/A	N/A	N/A
	Normally Open (NO)	N/A	N/A	N/A	Output (Low /COM)	Output (Hi)	N/A	N/A

### 4.2.1 Contact Closure/TTL Input and Normally Close (NC) Output connection diagram:

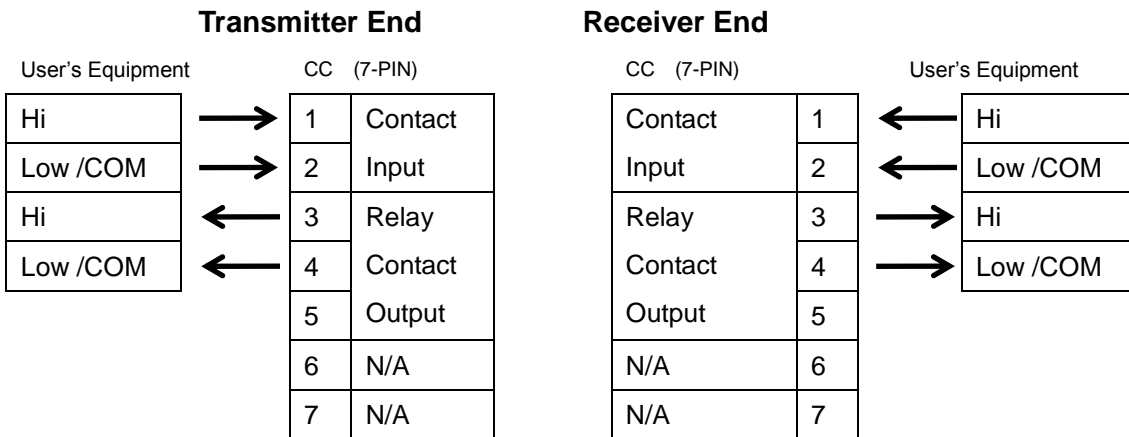

Fig. 4.4.1 Connector Pin Assignments for Contact Closure/TTL input and Normally Close (NC) output at CC port

### 4.2.2 Contact Closure/TTL Input and Normally Open (NO) Output connection diagram:

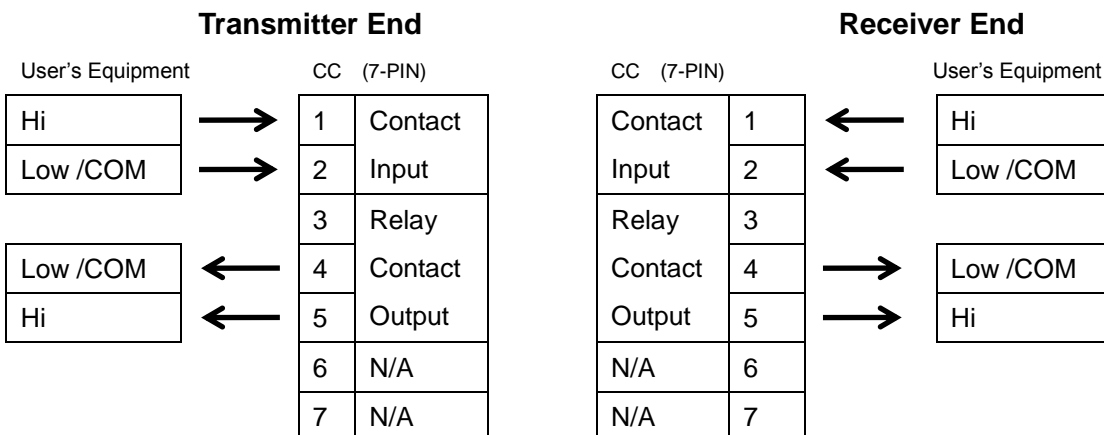

Fig. 4.4.2 Connector Pin Assignments for Contact Closure/TTL input and Normally Open (NO) output at CC port

### 4.3 Ground connection

For enhanced safety to reduce the risks of electrical shock and physical damage, caused by lightning and other power surges, as well as a connection to the surge suppression devices in the product, a screw terminal is provided on the Standalone cabinets (Fig. 4.5). It is highly recommended that the Standalone unit have good ground connections to the buildings ground in accordance with the local codes.

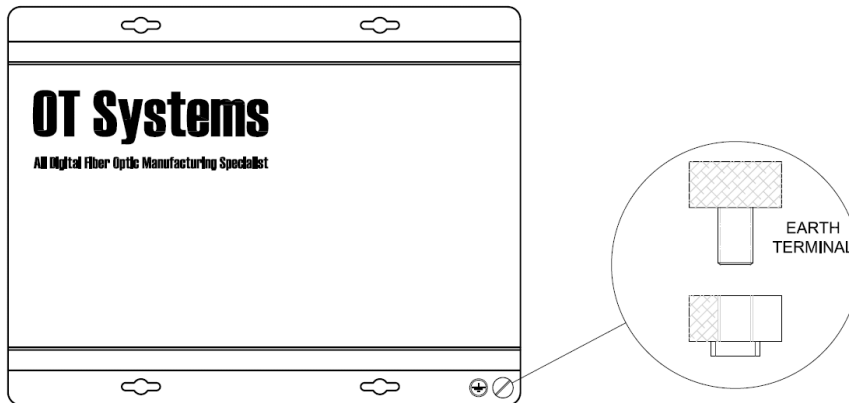

Fig. 4.5 Standalone unit earth terminal location

## (5) Operational Guides

### 5.1 FT210CB Series Transmitter

#### LED Indicators

Indicator	Color	Description	
PWR	Red	Lit when power is supplied to the Transmitter.	
OL	Yellow	Lit when optical signal from receiver to transmitter is active.	
VIDEO IN / VIN	V1-V2	Green	Lit when video signals are fed into the VIDEO IN connectors.
CC	IN	Red	Blinks when input CC is available at Tx.
	OUT	Green	Blinks when output CC is available at Tx.

#### Signal Ports

OPT -	ST (or FC) Optical Connector for fiber cable connection.
VIDEO IN -	BNC Video Connector for video signal input.
CC -	7-pin Screw Terminal Block for contact closure signal.

### 5.2 FT210CB Series Receiver

#### LED Indicators

Indicator	Color	Description	
PWR	Red	Lit when power is supplied to the Receiver.	
OL	Yellow	Lit when optical signal from transmitter to receiver is active.	
VIDEO OUT / VOUT	V1-V2	Green	Lit when video signals are received at VIDEO OUT connectors.
CC	IN	Red	Blinks when input CC is available at Rx.
	OUT	Green	Blinks when output CC is available at Rx.

#### Signal Ports

OPT -	ST (or FC) Optical Connector for fiber cable connection.
VIDEO OUT -	BNC Video Connector for video signal output.
CC -	7-pin Screw Terminal Block for contact closure signal.

## (6) Specifications

<b>MODELS*</b>	<b>FT210CB-SST(R)SA FT210CB-SST(R) (Single-Mode)</b>	<b>FT210CB-SST(R)LSA FT210CB-SST(R)L (Single-Mode)</b>	<b>FT210CB-SMT(R)SA FT210CB-SMT(R) (Multi-Mode)</b>
<b>PARAMETERS</b>			
<b>OPTICAL</b>			
No. of Fiber / Connector	1 / ST (or FC)	1 / ST (or FC)	1 / ST (or FC)
Wavelength	1310/1550 nm	1550/1310 nm	1310/1550 nm
Optical Power Budget	17 dB	24 dB	23 dB
Max Distance	40 km	60 km	4 km
<b>ELECTRICAL VIDEO</b>			
Channel / Connector	2/ BNC		
System	PAL, NTSC, SECAM		
Bandwidth	$\geq 6.0$ MHz		
Input/Output Impedance	75 Ohm		
Input/Output Level	1.0 Vp-p typical		
Differential Gain	< 1% typical		
Differential Phase	< 1° typical		
SNR	>65dB		
<b>CONTACT CLOSURE</b>			
Channel / Connector	1 / 7-pin Screw Terminal		
Direction	Bi-directional (Duplex)		
Input	Dry contact or TTL input		
Output	Dry contact, Normally Open (NO) or Normally Close (NC) Max. 32VDC/VAC@100mA		
<b>POWER</b>			
Power consumption	12VDC @ 4.8W		
Power Supply	Standalone Unit: FT/PA12V DC Adaptor Card module: Powered by FT-C18 chassis		
Connector (Standalone unit)	2-pin Screw Terminal		
<b>PHYSICAL</b>			
Weight	Standalone unit: 0.56 kg      Card module: 0.2 kg		
Dimensions (W x H x D)	Standalone unit: 156 x 30.5 x 223 mm (MAX) Card module: 148 x 20.4 x 213 mm (MAX)		
<b>ENVIRONMENTAL</b>			
Operating Temperature	-40°C ~ +75°C		
Storage Temperature	-40°C ~ +85°C		
Relative Humidity	0 ~ 95% non-condensing		
<b>MTBF</b>	>100'000 Hours		

\*If the optical connector is FC type, the suffix in the model number will be "-FXX". Eg. FT210CB-FST

## (7) Drawings

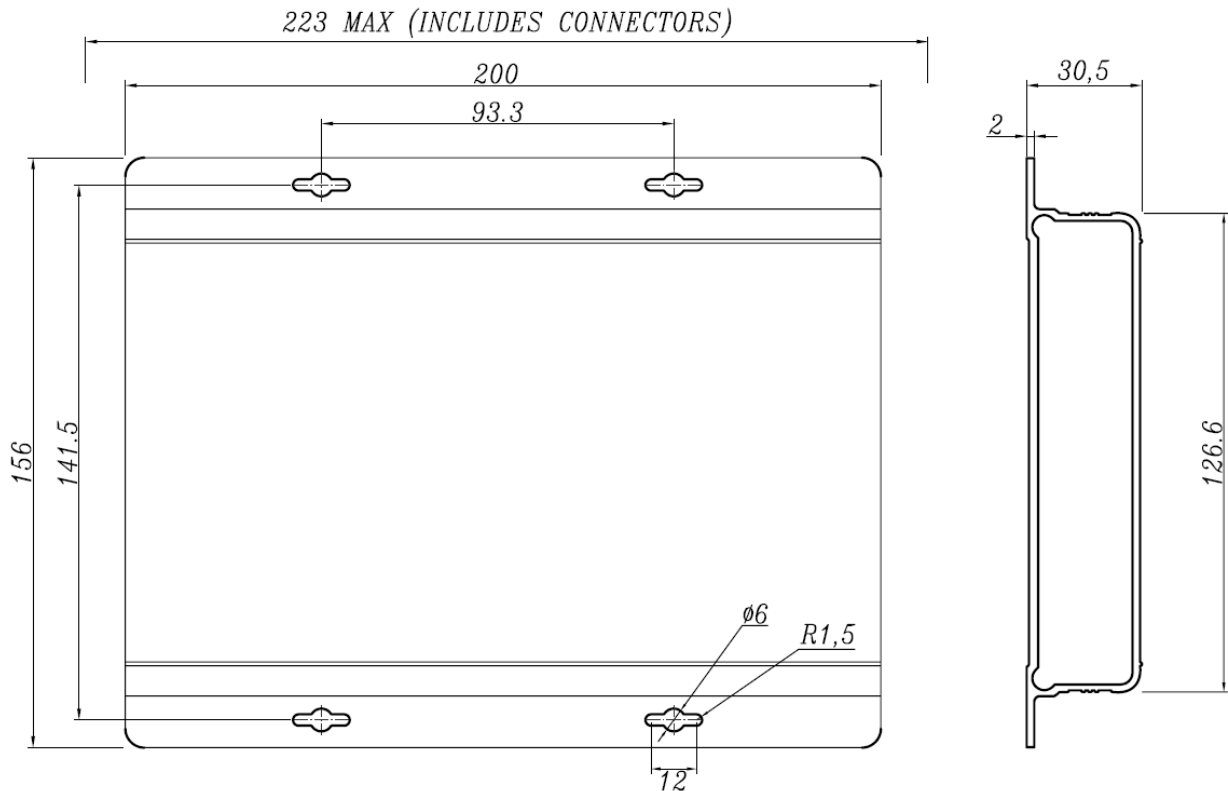

Fig. 7.1 Dimensional drawings of Standalone unit (mm)

## (8) Warranty Information

All OT Systems products are subject to a limited life-time warranty offered by the company in normal circumstances. Please refer to the OT Systems Products Warranty Statement for details. Access to the statement is available in our company website at [www.ot-systems.com](http://www.ot-systems.com).

## (9) Contact Information

### OT Systems Ltd. (Hong Kong)

Unit 1023, 10/F Landmark North  
 39 Lung Sum Avenue  
 Sheung Shui, N.T., Hong Kong  
 Tel. +852 2672 5153  
 Fax. +852 2679 0756  
[sales@ot-systems.com](mailto:sales@ot-systems.com)

### OT Systems Ltd. (USA)

River Heights Business Park  
 5375 US Highway 34  
 Oswego, IL 60543, USA  
 Tel. +1 630 554 9178  
 Fax. +1 630 554 9179  
[sales.usa@ot-systems.com](mailto:sales.usa@ot-systems.com)